

THREADED BODY CYLINDERS

with spring reset, single-acting, pmax. 400 bar



Application example: Multiple clamping fixture for the mass production of different workpieces (e. g. flange plates). The fixture is used in a rotary table. The clamping length is 600 mm. There are 48 pieces threaded body cylinders EZY-EM-020-015 and one rotary valve coupling DRG-5-EW-06-002 in use.

Description:

These threaded body cylinders are used as space-saving clamping cylinders and are notable for their compact design.

By the internal stroke limiters, the cylinder can also be operated even without a counter clamp surface. The use of the double wiper ring reduces dynamic leakage.

Operating conditions:

The threaded body cylinder is hydraulically operated, single-acting. Return is by means of a build-in spring. The hydraulic oil is fed through drilled holes.

The cylinder is sealed against the base of the screw-in hole by means of a ring seal. As a result of the plunger design, bleeding of the piston rod space is unnecessary.

Installation contour:

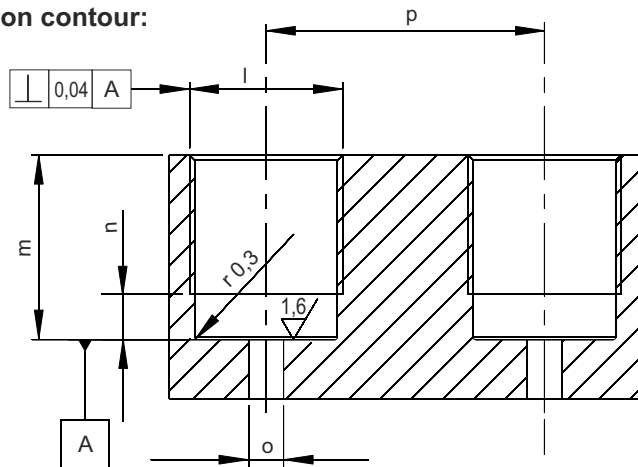

a Piston Ø	[mm]	12	16	20	25	32
r	[mm]	25	35	50	70	100
l	[mm]	M22x1,5	M26x1,5	M30x1,5	M38x1,5	M48x1,5
m (min./max.)	[mm]	15/26,5	19/33,5	23/42,5	26,5/45	40/71
n	[mm]	6	7	7	10	11
o max. Ø	[mm]	6	6	7	7	8
p min. without/with double wiper		25/31	30/34	35/40	43/52	55/62



Webcode: 021002

We also design and manufacture special designs

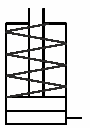

Important instruction:

The cylinder can be loaded up to the maximum clamping force in the retracted position.

Protect the cylinders against the direct influences of aggressive abrasives and coolants.

For general operating conditions and other information, read the catalogue page "Recommendations & Specifications".

Sealing:

- ⊗ NBR, Operating temperature: -10° up to +80°C
- ⊗ FKM, Operating temperature: up to max. 150°C

Advantages:

- ⊗ Space-saving installation
- ⊗ Suitable without counter clamping surface
- ⊗ Also retracted fully loadable
- ⊗ Extremely low leakage
- ⊗ Ventilation connection unnecessary

HYDROKOMP®
Hydraulische Komponenten GmbH

Siemensstraße 16, 35325 Mücke (Germany)
Phone: +49 6401 225999-0
Fax: +49 6401 225999-50
E-mail: info@hydrokomp.de
Internet: www.hydrokomp.de



Threaded body cylinders / Designs

Threaded body cylinder with spring reset

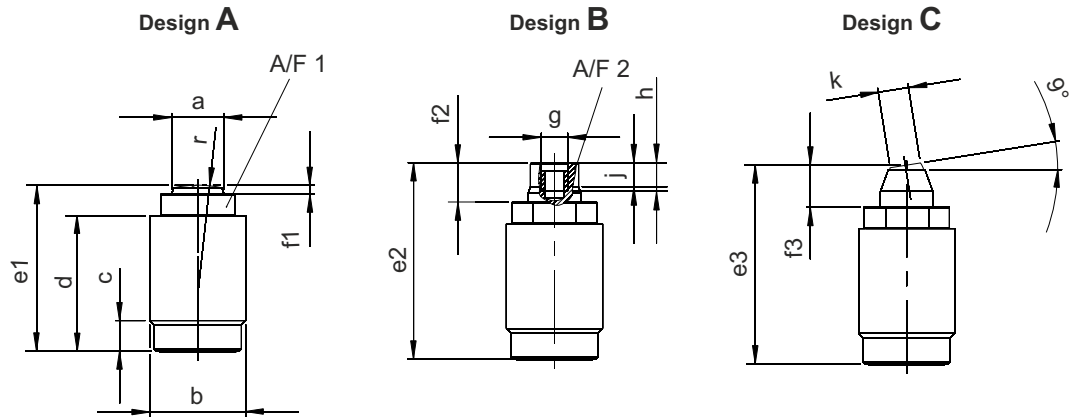

Threaded body cylinder with spring reset and double wiper

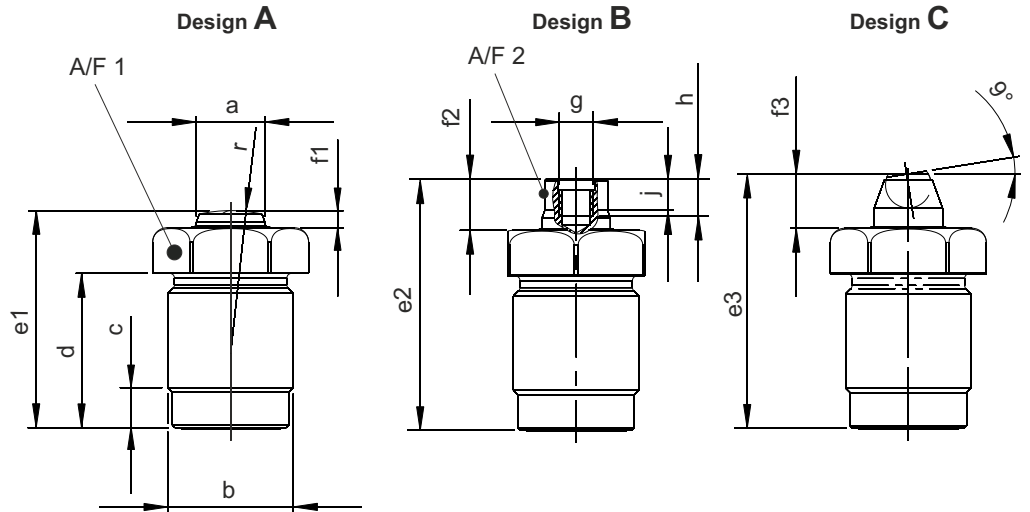

a Piston Ø	[mm]	12	16	20	25	32
Stroke	[mm]	10	12	15	16	20
Clamping force at 100 bar	[kN]	1,1	2	3,1	4,9	8
Clamping force at 400 bar	[kN]	4,5	8	12,5	19,6	32
Spring reset load min.	[N]	30	50	75	125	200
Oil requirement/10 mm stroke	[cm ³]	1,13	2,01	3,14	4,91	8,04
b	[mm]	M22x1,5	M26x1,5	M30x1,5	M38x1,5	M48x1,5
c	[mm]	7	8	8	11	12
d without/with double wiper	[mm]	31/27	35/34	44,5/43	45/45,5	72,5/71,5
e1	[mm]	38	45,5	56	59,5	87
e2	[mm]	45	51,5	65,5	68,5	98
e3	[mm]	45,5	53	69,5	72,5	100
f1 without/with double wiper	[mm]	2/3	2,5/3	2,5/4	3,5/5	3,5/7
f2 without/with double wiper	[mm]	9/10	7,5/9	12/13,5	12,5/14	14,5/18
f3 without/with double wiper	[mm]	9,5/10,5	9/11	16/17,5	16,5/18	16,5/20
g	[mm]	M6	M6	M8	M8	M12
h	[mm]	6,5	6,5	8	8	12
j	[mm]	5,5	5,5	6	7	9
k Ø	[mm]	7	7	10,5	10,5	20
A/F 1 without/with double wiper	[mm]	17/24	22/27	24/32	32/41	41/50
A/F 2	[mm]	10	13	17	19	24
r	[mm]	25	35	50	70	100
Starting torque	[Nm]	40	50	60	80	225
Weight	[kg]	0,08	0,15	0,22	0,38	0,97
Order number:						
without double wiper	EZY-EM-					
Design A		...12-10-AX001	...16-12-AX001	...20-15-AX001	...25-16-AX001	...32-20-AX001
Design B		...12-10-BX001	...16-12-BX001	...20-15-BX001	...25-16-BX001	...32-20-BX001
Design C		...12-10-CX001	...16-12-CX001	...20-15-CX001	...25-16-CX001	...32-20-CX001
with double wiper	EZY-EM-					
Design A		...12-10-AX002	...16-12-AX002	...20-15-AX002	...25-16-AX002	...32-20-AX002
Design B		...12-10-BX002	...16-12-BX002	...20-15-BX002	...25-16-BX002	...32-20-BX002
Design C		...12-10-CX002	...16-12-CX002	...20-15-CX002	...25-16-CX002	...32-20-CX002
Bottom seal NBR (Spare part, 1 pce)		6014-011	6022-004	6025-026	6030-008	6042-003
Bottom seal FKM (Spare part, 1 pce)		6014-013	6022-006	6025-034	6030-009	6042-004

Sealing material: Replace the **X** in the order number by a **P** for NBR or a **V** for FKM. (Example: EZY-EM-20-15-BV001)